

VISION SENSORS



The easy way to machine vision

- Fully embedded vision sensor
- 3.5" VSC configurator
- 7 different controls
- Memorisation of 8 inspections



The **SVS1** series is the easiest solution for machine vision applications. The setup is very quick and intuitive thanks to the VSC unit, the external configurator with 3.5" colour display. The sensor setting is carried-out through three simple steps: region of interest definition, control type selection, parameter adjusting. The **SVS1** is a fully embedded vision sensor able to acquire images, control them and activate the digital outputs according to the result. The VSC unit can provide a real time monitoring of the images, but it is not required during the functioning of the sensor and so it can be disconnected and used to setup multiple sensors. **SVS1** is able to carry-out 7 different controls: Brightness, Contrast, Position, Width, Edge counting, Pattern match, OCV. Its flexibility together with the VSC configurator make the sensor ideal for plants with frequent format changes (packaging, food, cosmetic, bottling, labelling, ...).

The extremely compact size of the SVS sensors is not an obstacle for the full integration of all the elements for a reliable image-based control.

- Compact housing
- 640 x 480 image sensor
- VSC configurator with 3.5" colour display, 8 push-buttons, 8 LEDs
- Red light LED illuminator
- Selectable lenses
- Standard M12 connectors
- Configurator preset for DIN rail or panel mounting
- 3 PNP outputs
- 4 signalling LEDs: output1, output2, power supply, communication

DIMENSIONS

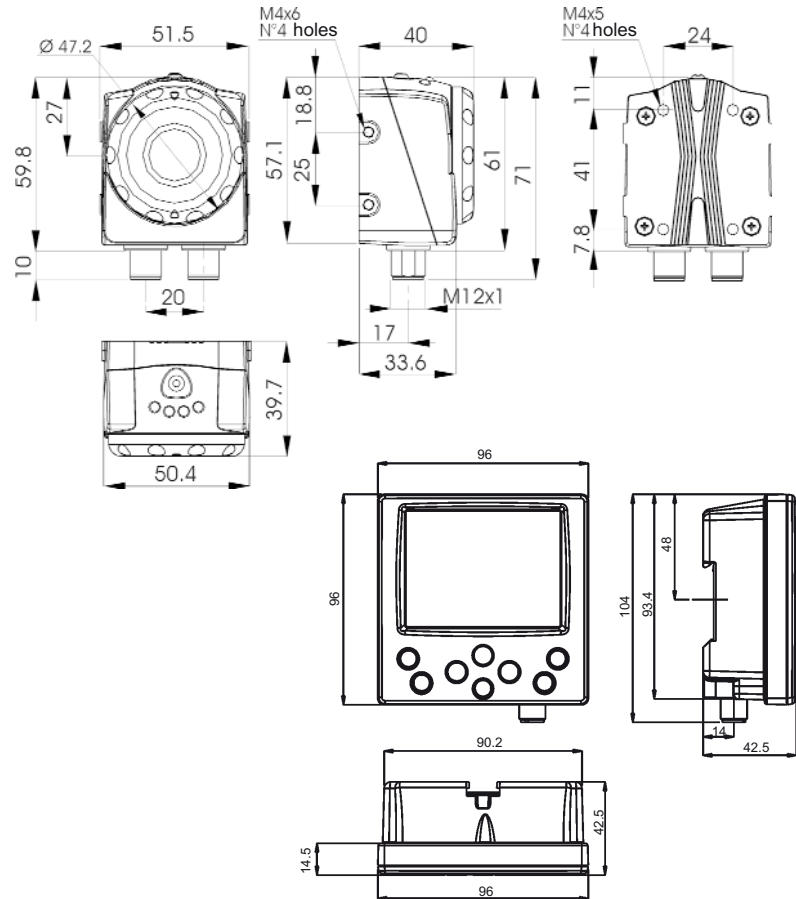

mm

INDICATORS



- A Power supply, green
- B Digital output 2, yellow
- C Digital output 1, yellow
- D VSC connection, green



- A Setting mode, green
- B Adjust mode, green
- C Monitor mode, green
- D Main menu, green
- E Power supply, green
- F Digital output 1, yellow
- G Digital output 2, yellow
- H Sensor connection, green

CONNECTIONS

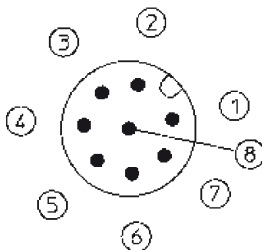

M12 8-POLE (VSC connection)

- PIN 1 = Ethernet TX+
- PIN 2 = Ethernet RX+
- PIN 3 = Ethernet RX-
- PIN 4 = Not used
- PIN 5 = 24 Vdc
- PIN 6 = Not used
- PIN 7 = Ethernet TX-
- PIN 8 = GND



M12 8-POLE (power supply and I/O)

- PIN 1 = white = digital input 1
- PIN 2 = brown = 24 Vdc
- PIN 3 = green = STROBE for external illuminator
- PIN 4 = yellow = output 1
- PIN 5 = grey = output 2
- PIN 6 = pink = output 3
- PIN 7 = blue = GND
- PIN 8 = red = external trigger



TECHNICAL DATA

Power supply:	24 Vdc $\pm 10\%$ ¹
Ripple:	1 Vpp max with illuminator 2 Vpp without illuminator
Consumption (SVS1+VSC):	300 mA @ 24 Vdc (illuminator excluded)
Output type:	3 PNP
Output current:	100 mA max
Saturation voltage:	< 2 V
VSC connection:	M12 8-pole A-code
External illuminator interface:	Strobe signal (TTL)
Frame rate:	60 fps
Optics:	integrated (6 mm / 8 mm / 12 mm)
Setting:	VSC configurator
Sensor indicators:	4 LEDs
VSC indicators:	8 LEDs
Connections:	2 x M12 8-pole A-code
Mechanical protection:	IP50 (SVS1) IP40 (VSC)
Protection devices:	A, B ²
Housing material:	aluminium alloy / ABS
Sensor weight:	125 g
VSC weight:	170 g
Operating temperature:	-10 ... +50°C
Storage temperature:	-25 ... +70°C

¹ Limit values

² A - reverse polarity protection
B - overload and short-circuit protection



FIELD OF VIEW

Operating distance (mm)	SVS1-12-DC-S	SVS1-08-DC-x	SVS1-06-DC-S
50	17x12	25x20	42x30
80	25x20	40x30	60x41
110	33x25	55x40	80x55
140	45x35	70x50	98x69
170	53x38	85x65	118x83
200	60x50	100x70	138x92
300	90x65	145x103	201x140
400	121x82	186x132	265x189
500	150x110	236x167	330x232
600	185x130	282x232	385x270

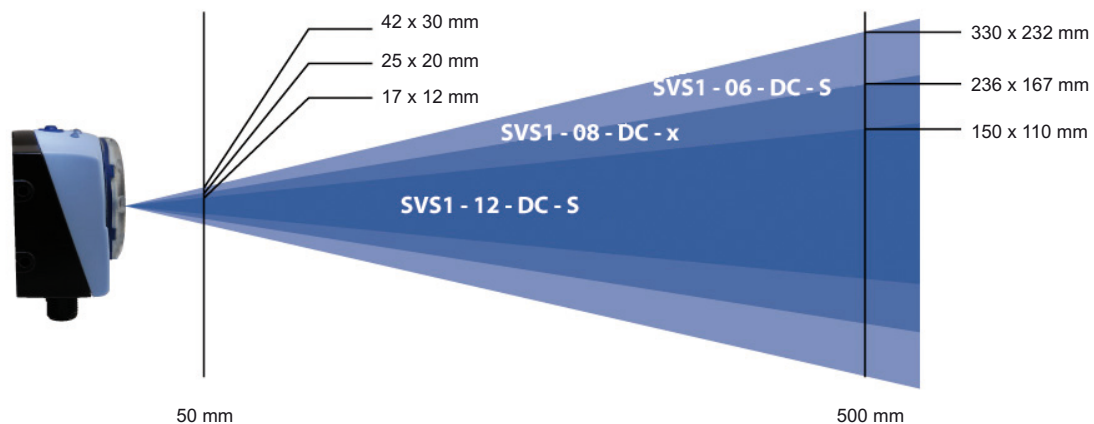

SVS1 CONFIGURATION



The configuration of SVS1 sensors is obtained exclusively via VSC unit. No PC is necessary and thus sensor setting is easy and quick. Once the configuration has been completed, the VSC display can be used to visualise inspection results in real time or to configure a new sensor.

The interface available on the configurator, composed of 8 signalling LEDs and 8 push-buttons, allows the operator to quickly and intuitively set the sensor functioning parameters.

PUSH-BUTTONS	
Push-button label	Main functions
Status	Go to next configuration step
Teach	Setting memorisation Acquisition of a new reference image
Set	Confirmation of option selected Confirmation of parameter value Monitor mode change
Esc	Exit without saving Return to previous panel Return to previous configuration step
Arrows	Change of option selected Movement/resizing of ROI Parameter change



Step 1: Image adjustment and control definition



In the first configuration step, the user has to set the sensor parameters in order to obtain a good image quality in terms of focus, brightness and contrast. The control type and the part to inspect have to be then defined.

Step 2: Parameter setting

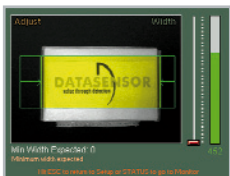

The second configuration step consists in setting the functioning parameters of the control previously selected and the acceptance thresholds.

Step 3: Inspection check and memorisation

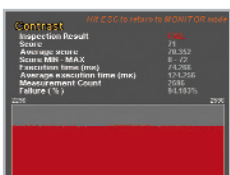

The third step consists in the control of the correct inspection functioning and the saving on the sensor memory. Once completed, the configuration has ended and the sensor can operate in a stand-alone mode.



EXCELLENT FLEXIBILITY

Password

A Password that prevents the access to the configuration parameters to unauthorised personnel can be defined.



Fail inspector

The latest 8 inspected parts that have caused a control failure can be recalled by the Fail Inspector. This tool provides an immediate control of the production non-conformities.

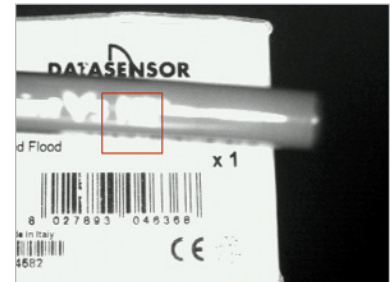
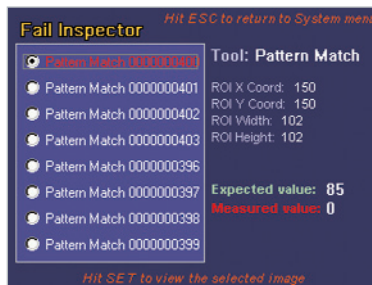

Inspection selection

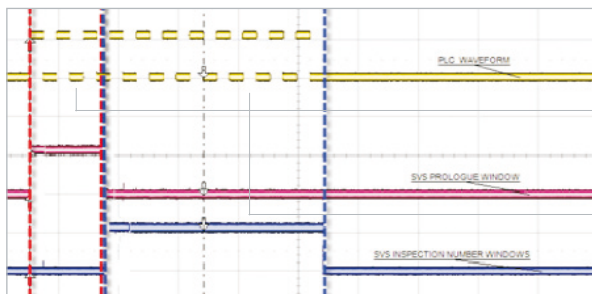

Preamble

Counting



Each inspection is composed of a template and parameters. A specific inspection can be thus referred to different products in progress on the same production line. The different inspections are recalled using digital pulses on pin1 (white). The example provided shows that after a 3 pulse preamble, the successive 8 pulses are counted for the selection of the eighth inspection.

The inspection change can be carried-out also directly by the operator using the bankset manager panel.

MONITORING USE OF THE VSC

Standard mode



Camera mode



Zoom mode

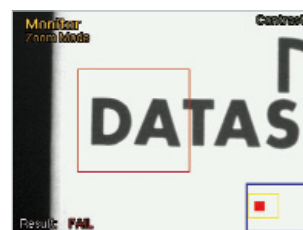

Fail mode





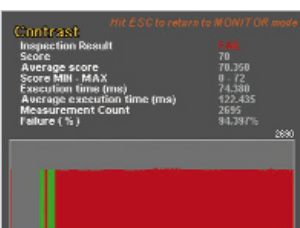



Production statistics



Besides the four monitoring modes, indicated above, the VSC configurator can visualise some production statistics, such as the number of inspected items and percentage of non-conformities.

CONTROL TABLE

Seven different controls able to cover the most varied applications.

Control	Functioning	Applications	Image
Pattern Match	Searches a template inside a specific area	Packaging: logo check Assembling: product orientation Post automation: stamp check	
OCV	Control of printed character quality	Packaging: production lot control Food: expiry date control	
Position	Check of object border position	Bottling: liquid level control Food: label position control	
Width	Measures object width	Assembling: plastic part control Wood industry: branch thickness measurement	
Counting	Counts the objects along a line	Electronics: component counting Pharmaceutical: blister stack counting	
Contrast	Contrast calculation	Food: date and lot presence control Metal working: laser marking control	
Brightness	Brightness calculation	Bottling: cap presence control Packaging: object counting	

APPLICATIONS

SVS1 is ideal for the control of text presence in overprinting and logo position on food packages, product completeness before packaging, logo position on cosmetic bottles, correct stamp on post envelopes, liquid level inside a plastic bottle, correct product orientation on a conveyor belt, expiry date or lot number integrity.

Surface control

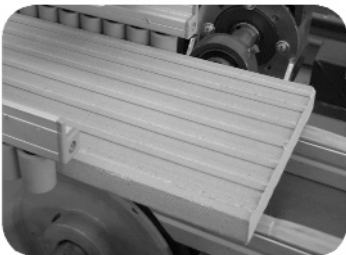

Part orientation



Expiry date integrity



Level control



Product conformity

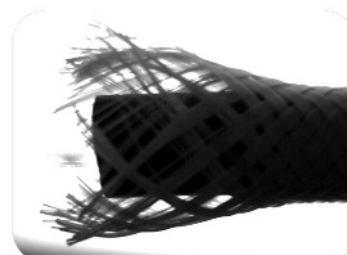

Bottling check

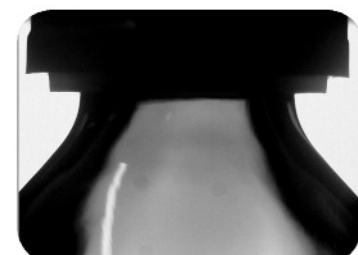



ACCESSORIES

ST-5066 U-shaped fixing bracket for angle adjustment

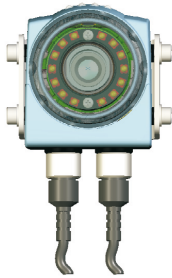
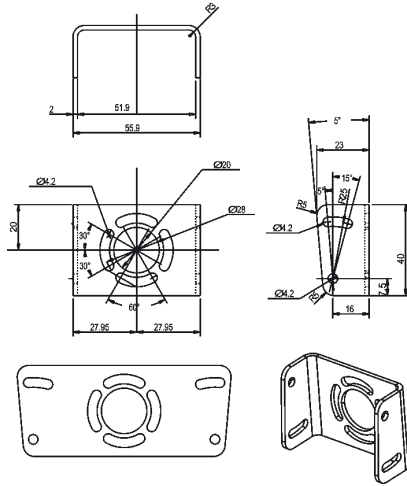

ST-5068 L-shaped fixing bracket for 90° mounting

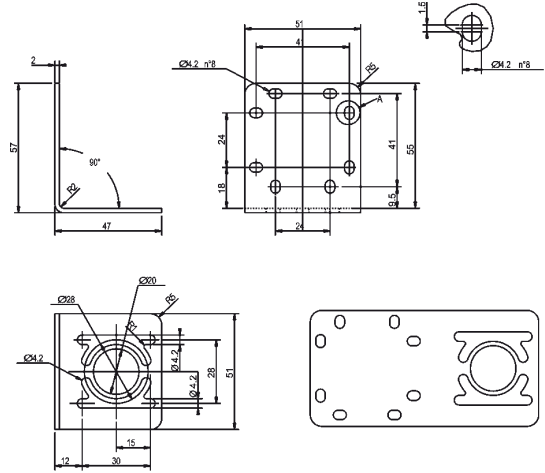

MOUNTING KIT

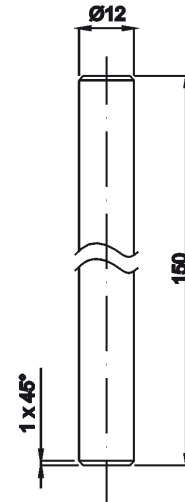
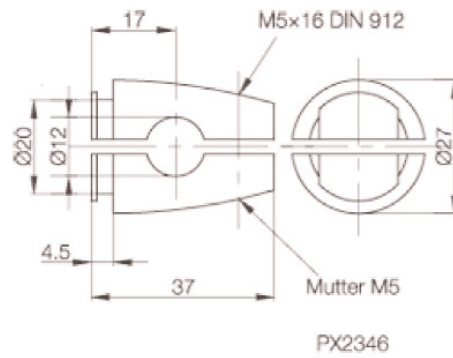
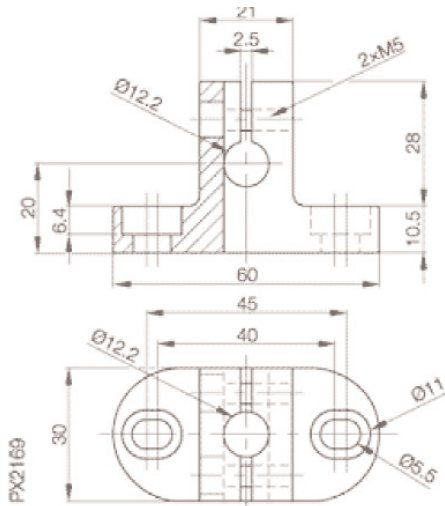

MODEL SELECTION AND ORDER INFORMATION

MODEL	INTEGRATED ILLUMINATOR	VSC INCLUDED	CABLES INCLUDED	DIGITAL INPUTS	DIGITAL OUTPUTS	ORDER N°
SVS1-08-DC-K	•	•	•	1	3	959941000
SVS1-06-DC-S	•			1	3	959941010
SVS1-08-DC-S	•			1	3	959941020
SVS1-12-DC-S	•			1	3	959941030

ACCESSORY SELECTION AND ORDER INFORMATION

MODEL	DESCRIPTION	ORDER N°
CS-A1-06-B-03	M12 8-pole connector with 3 m unshielded cable	95ACC2230
CS-A1-06-B-05	M12 8-pole connector with 5 m unshielded cable	95ACC2240
CS-A1-06-B-10	M12 8-pole connector with 10 m unshielded cable	95ACC2250
SVS-CV-VSC-02	2 m SVS-VSC connection cable	95A901360
SVS-CV-VSC-04	4 m SVS-VSC connection cable	95A901370
SVS1-VSC	VSC configurator	959941040
SVS1 UPDATING KIT	Updating kit	95A901540
SVS-ST-5068	L-shaped fixing bracket for 90° mounting	95A901320
SVS-ST-5066	U-shaped fixing bracket for angle adjustment	95A901330
SVS-MK-01	Mounting kit	95A901380

VISION SENSORS



HEADQUARTERS

DATASENSOR SpA
via Lavino, 265 - 40050 Monte San Pietro, BO - Italy

Datasensor SpA endeavours to continuously improve and renew its products; for this reason the technical data and contents of this catalogue may undergo variations without prior notice. For correct installation and use Datasensor SpA can guarantee only the data indicated in the instruction manual supplied with the products.